

ASB-328-27-039**Title: Inspection of the Elevator Pulley Support Bracket****1. PLANNING INFORMATION****Effectivity**Dornier 328-100.
EASA TCDS A.096.
Serial-No's: All aircrafts**Reason**

Heavy corrosion has been found on elevator pulley bracket 001A273A3011201.

Description

Inspection for signs of corrosion and cracks on the elevator pulley brackets 001A273A3011200 and -201 on all Dornier 328-100 aircrafts.

Compliance

This Alert bulletin must be performed not later than 31th of January 2012.

Approval

The technical content of this Alert Service Bulletin is approved under authority of EASA approved design organization 328 Design GmbH (EASA.21J.438).



328 Support Services GmbH is TC-Holder of Dornier 328 Jet and Prop and authorised to provide necessary approved data. Any Dornier 328 approved data will be established and verified by 328 Design GmbH as authorised and responsible Dornier 328 Design Organisation per EASA approval EASA 21J.438. For details in this matter please contact 328 Support Services GmbH or EASA.

It is the operator's responsibility to comply with the relevant aviation regulations of the country in which the aircraft is registered.

Model	<u>Dornier 328-100</u>	Rev. No.	_____	No.	<u>ASB-328-27-039</u>
		Rev. Date.	_____	Date of Issue	<u>Dec. 16, 2011</u>
				Page	<u>1</u> of <u>4</u>

Manpower

Access:	1,0 Mhrs.
Inspection:	3,0 Mhrs.
Close-up:	1,0 Mhrs.
Reporting:	1,0 Mhrs.
Functional checks:	0,0 Mhrs.
Total:	6,0 Mhrs.

Material

Corrosion preventive compound (CML15-004 or CML15-007)

Special Tools

Visual inspection equipment, see NTM 51-25-90, flash light or other suitable light source, mirror, flexible endoscope (if required to gain full inspection coverage of the area, see figures 1 and 2)

Eddy current inspection equipment, see NTM 51-25-60 (KAS 66-3 probe and Elotest M2 or equivalent)

Weight and Balance

Not affected

Electrical Load Data

Not affected.

References

AMM JIC 05-29-30-210-805-A01 Rear Fuselage – General Visual Inspection
CML
NTM 51-25-60 Eddy Current
NTM 51-25-90 Visual Inspection

Other Publications Affected

Not affected

Reporting

Compliance this Alert Service Bulletin must be reported to 328 Support Services GmbH Customer Services Department using the Compliance Report for Configuration Control. Please report inspection results in form of meaningful pictures and NDT reports.

2. ACCOMPLISHMENT INSTRUCTIONS

A Preparation

CAUTION: Obey the Safety Precautions and the General Maintenance Practices according to the AMM JIC Chapter 00.

WARNING: Put a warning notice in the flight compartment to tell persons not to operate the flight controls.

- (1) Make the aircraft safe for maintenance according to AMM JIC 00-30-01.
- (2) Open access panel 311-AB to gain access to the inspection area.
- (3) Ensure that parts, which have to be inspected, are thoroughly cleaned prior to inspection.

B Inspection

- (1) Perform a detailed visual inspection according to NTM 51-25-90 for any signs of corrosion and cracks on elevator pulley support brackets and mating parts, see fig. 1 for concerned area. Use appropriate light source, mirror and/or flexible endoscope for inspection from the bottom side.
- (2) Perform eddy current testing for detection of cracks or corrosion according to NTM 51-25-60 on areas shown in figure 2 with focus on the outer edges of the ribs and the bottom of the milled pockets.
A suitable equipment is an Elotest M2 testing device and a KAS 66-3 probe or equivalent equipment (suitable frequencies range from 500 to 700 kHz).

C Close-up

CAUTION: Corrosion preventive compounds must not be applied on movable parts of flight controls.

- (1) Perform a foreign object inspection to the inspected area.
- (2) Re-apply corrosion preventive compound.
- (3) Close all opened access doors and panels according to related AMM JICs.
- (4) Remove the warning notice from the flight compartment.
- (5) Return the aircraft into a flyable status.

Model Dornier 328-100 Rev. No. _____

No. ASB-328-27-039

Rev. Date. _____

Date of Issue Dec. 16, 2011

Page 3 of 4

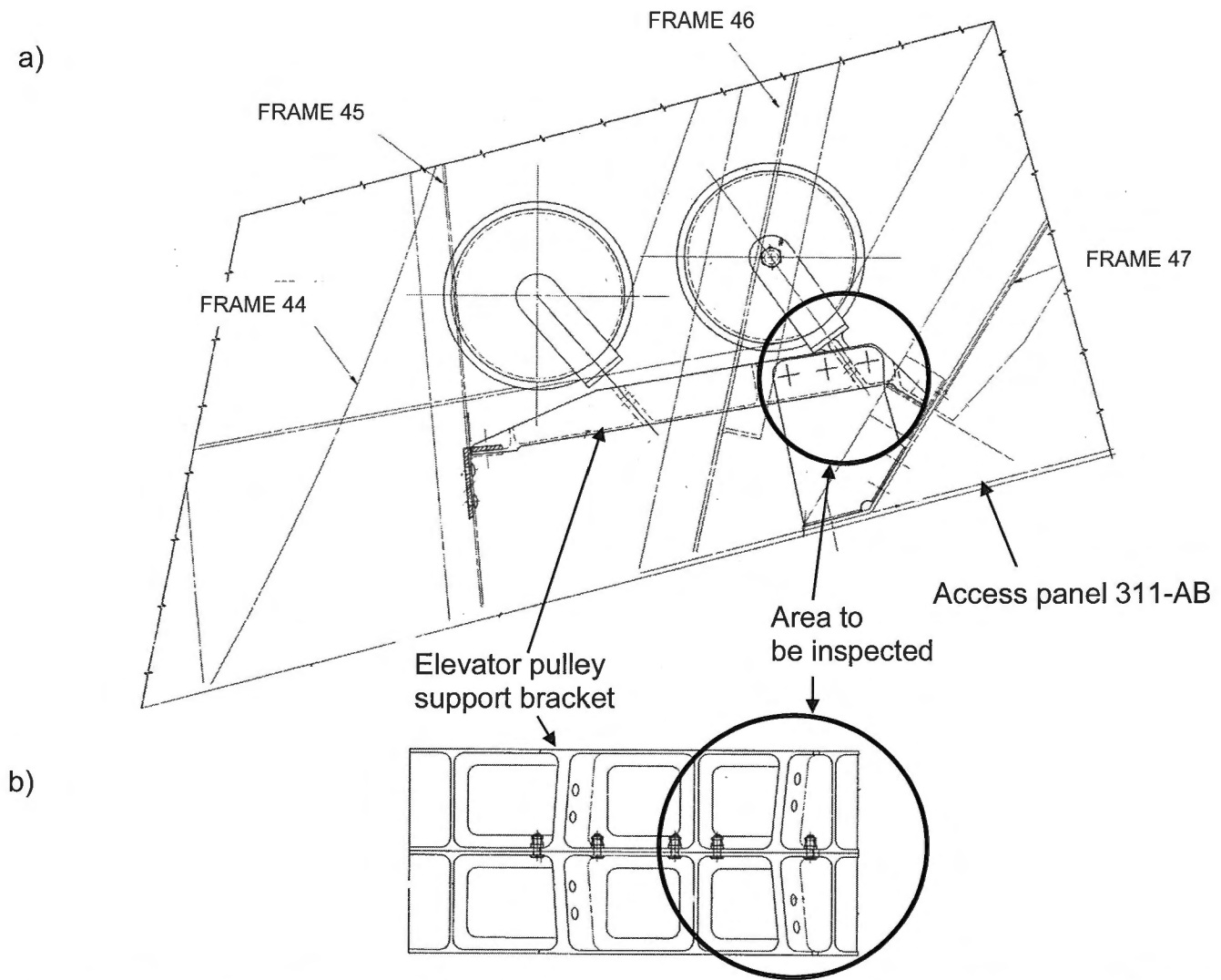

Figure 1: Elevator pulley support brackets in a) installation and in b) Assembly without pulleys

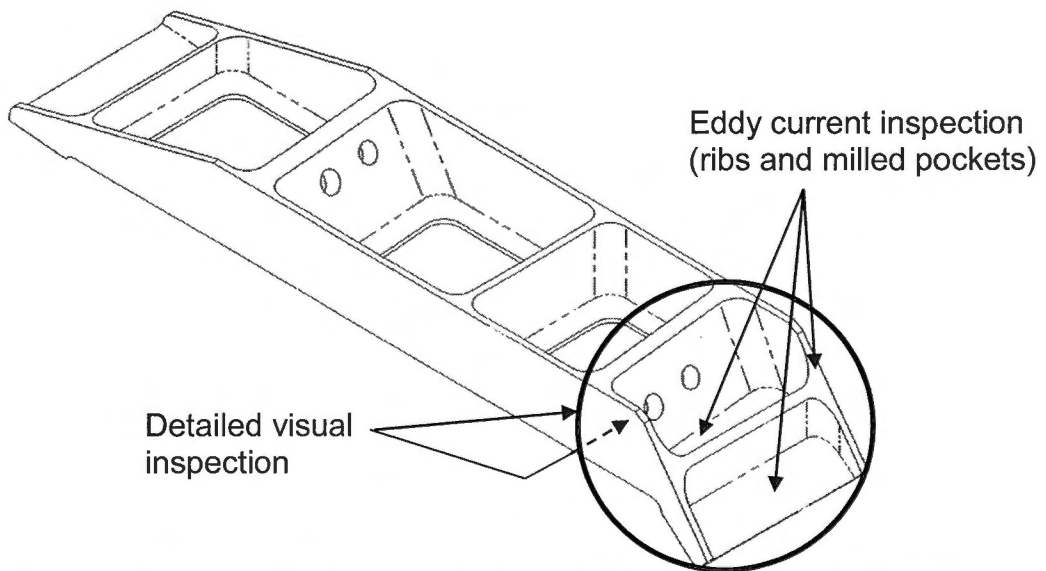

Figure 2: Inspection areas on brackets 001A273A3011200 (shown) and -201 (symmetric).



Dornier 328/328J Compliance Report



328 Support Services GmbH
 Customer Services Global Support Center
 P. O. Box 1252 Phone +49 (0) 8153 88111-6666
 D-82231 Wessling Telefax +49 (0) 8153 88111-6565
 Fed. Rep. of Germany e-mail gsc.op@328support.de

Please complete this Compliance Form for each aircraft only when it is applicable, and mail or fax to:

Attention: **Dept. P1**
 328 Support Services GmbH
 Customer Services
 P.O. Box 1252
 D-82231 Wessling
 Fax +49 (0) 8153 88111 - **6565**

From Company: _____

AOT No.:	Rev.:	Title:

ASB No.:	Rev.:	Title:

SB No.:	Rev.:	Title:

EO No.:	Rev.:	Title:

Aircraft Type & Serial Number: _____

Operator: _____

Total Flight Hours: _____ Total Landings: _____

Date of compliance: _____

Comments: _____

 Date

 Authorized signature