



Revision Transmittal Sheet

This sheet transmits Revision 2 of Alert Service Bulletin ASB-328-28-041 titled:
Fuel – Inspection of fuel line clamps.

This is a complete revision. This has been reprinted in its entirety. All previous editions must be destroyed.
For A/C already inspected according to previous revisions of this ASB; immediate recurrence of this ASB is not required. Obey the repeat inspection interval of 2500 FH.

Reason for Revision:

Implementation of replacement limits for chafing marks found on jet pump inlet, connection part and fuel lines.

Removed reference to SB-328-28-484.

Changed location designators from “1-4” to “A-D”. (Fuel clamp inspection location)

Editorial corrections

NOTE: The changes are marked with revision bars at the outside margin.

This Revision Transmittal Sheet is part of ASB-328-28-041 Revision 2 .

Model: Dornier 328-100

No.: ASB-328-28-041

Date of Issue: Dec 12, 2016

Page 1 of 1



ASB-328-28-041

Title: Fuel – Inspection of Fuel Line Clamps

1 PLANNING INFORMATION

Effectivity

Dornier 328-100

Type Certificate Data Sheet EASA.A.096

Serial No.: All aircraft post SB-328-28-490.

Reason

Chafing of fuel line clamp bonding wires inside feeder tank.

Description

328 SSG received reports of damaged bonding wires on fuel line clamps in post SB-328-28-490 installations. The basic clamp function is not impaired, but proper bonding and thus lightning protection might be affected. Refer to Figure 1.

In addition, chafing marks on jet pump inlet, connection part and fuel lines occurred.

Parts with chafing marks beyond defined limits have to be replaced.

Approval

The technical content of this Alert Service Bulletin is approved under the authority of EASA approved design organization 328 Design GmbH (EASA.21J.438).

This inspection is covered by type design.



© 328 Support Services GmbH 2006-2017. All Rights reserved.

This document is property of 328 Support Services GmbH and is supplied on the condition that it is treated as confidential. No use or reproduction may be made thereof other than that expressly authorized. The information provided by this ASB has been prepared for a specific Serial Number(s) aircraft, component, component part number or specific problem on the basis of the information supplied to 328 Support Services GmbH. The information provided by 328 Support Services GmbH is not to be used for any other specific serial Number(s) aircraft, component, component part number or any other purpose than for that which it was supplied without the written approval of 328 Support Services GmbH.

Any information contained in this ASB are Technical Documents and Data as defined in the Technical Data Agreement which 328 Support Services GmbH has separately concluded with the Customer. The Technical Data Agreement, especially the confidentiality obligations contained therein applies to any information provided by 328 Support Services GmbH in the course of the fulfilment of the ASB.

328 Support Services GmbH is the TC-Holder of Dornier 328-100 and 328-300 and authorised to provide necessary approved data. Any Dornier 328 approved data will be established and verified by 328 Design GmbH as authorised and responsible Dornier 328 Design Organisation per EASA approval EASA 21J.438. For details in this matter please contact 328 Support Services GmbH or EASA.

It is the operator's responsibility to comply with the relevant aviation regulations of the country in which the aircraft is registered.

Model: Dornier 328-100

Rev. No.: 2

No.: ASB-328-28-041

Rev. Date: Dec 12, 2016

Date of Issue: Jun 14, 2016

Page 1 of 7

Compliance

Mandatory. Perform this ASB latest at next A-check.
Repeat inspection with interval of 2500 FH.

Manpower

Access:	1,0 Mh
Inspection:	1,5 Mh
Close-up:	1,0 Mh
Functional checks:	1,5 Mh
Defueling/Refueling:	2,5 Mh
Total:	7,5 Mh

Material

Refer to Material Parts List.

Special Tools

Not necessary.

Weight and Balance

The weight and balance data in the Basic Weight Balance Record are not affected.

Electrical Load Data

Not affected.

References

SB-328-28-490 Fuel – Replacement of Fuel Lines

Other Publications Affected

None.

Reporting

Compliance with this Alert Service Bulletin must be reported to 328 Support Services GmbH Global Support Centre with the Compliance Report for Configuration Control. Fill in the tables below figure 2 on page 5 and attach it to the Compliance Report.

2 ACCOMPLISHMENT INSTRUCTIONS

CAUTION: Obey the General Maintenance Practices and Safety Precautions.

Refer to AMM JIC Chapter 00, in particular:

00-30-10 General Maintenance Practices

00-30-28 Safety Precautions Fuel System

A Preparation

- 1) Make the aircraft safe for maintenance, refer to AMM JIC 00-30-01.
- 2) Defuel aircraft, refer to AMM JIC 12-11-40-650.
- 3) Open/remove all doors, covers, panels, and removable fairings as necessary to get access to the modification area, refer to AMM JIC 06-40-02-500.

B Modification

- 1) Inspect all Hydraflow fuel line clamps at locations A - D for damage of bonding wires in the area. Take pictures of each location for reporting purposes. Refer to Figure 2.
- 2) Open clamps and remove them from tank. Record installation locations.
- 3) Visually inspect clamps for worn or missing bonding wires. If you find worn or missing bonding wires, replace clamp and report the location.
- 4) Visually inspect the jet pump outlet, connection part and fuel lines for chafing marks. Remove parts from tank if chafing marks are found. Refer to the related AMM JIC's.

- 5) Measure depth of chafing marks and compare to the replacement limits defined in table 1.

Table 1: Replacement Limits

Part / P/N	Replacement Limit
Jet pump outlet/ 219335-3	> 0,8 mm > 0.032"
Tube assy/ 001A282A3099200	> 0,5 mm > 0.019"
Tube/ 001A282A3235000	> 0,5 mm > 0.019"
Tube/ 001A282A3235001	> 0,5 mm > 0.019"
Connection part */ 001A282A1020200	> 0,5 mm > 0.019"
Tube assy/ 001A282A3715000	> 0,5 mm > 0.019"

- 6) Discard parts if depth of chafing is more than the replacement limits.
- 7) Install new parts, and all parts removed in step 4) which are in the replacement limits, to tank. Refer to SB-328-28-490.
- 8) Check installation of jet pumps, connection part and fuel lines for correct alignment and correct if necessary. Maximum allowable deviation is 1 mm.
- 9) Install clamps. Refer to SB-328-28-490. Make sure the alignment is correct

C Close-up

- 1) Do a foreign object inspection of the complete modification area.
- 2) Close/install all doors, covers, panels, and fairings opened/removed before, refer to AMM JIC 06-40-02-500.
- 3) Refuel aircraft, refer to AMM JIC 12-11-10-650.
- 4) Do an engine ground run, refer to AMM JIC 71-01-00-500.
- 5) Return the aircraft to a serviceable condition.

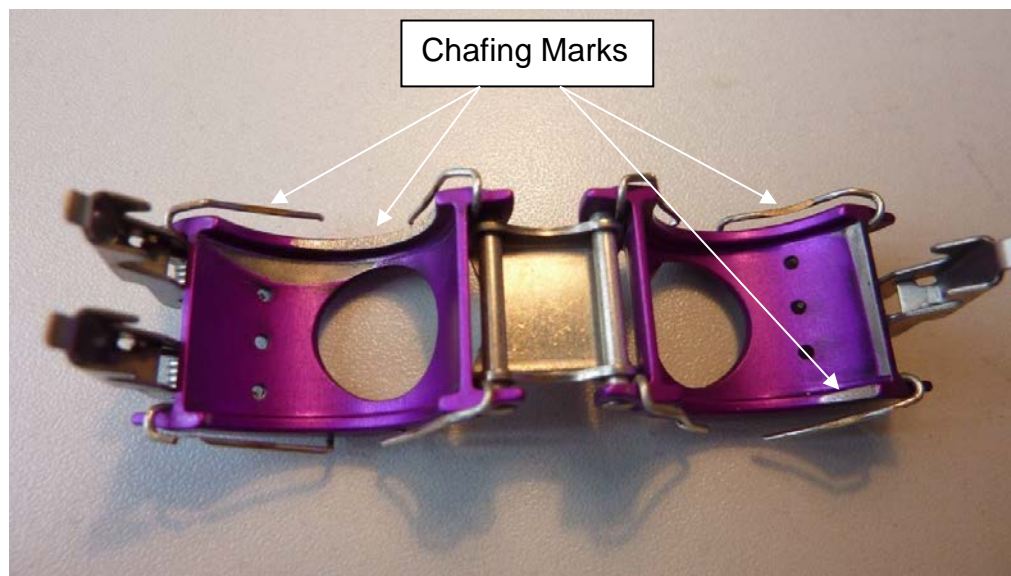

Figure 1: Examples of Reported Damage

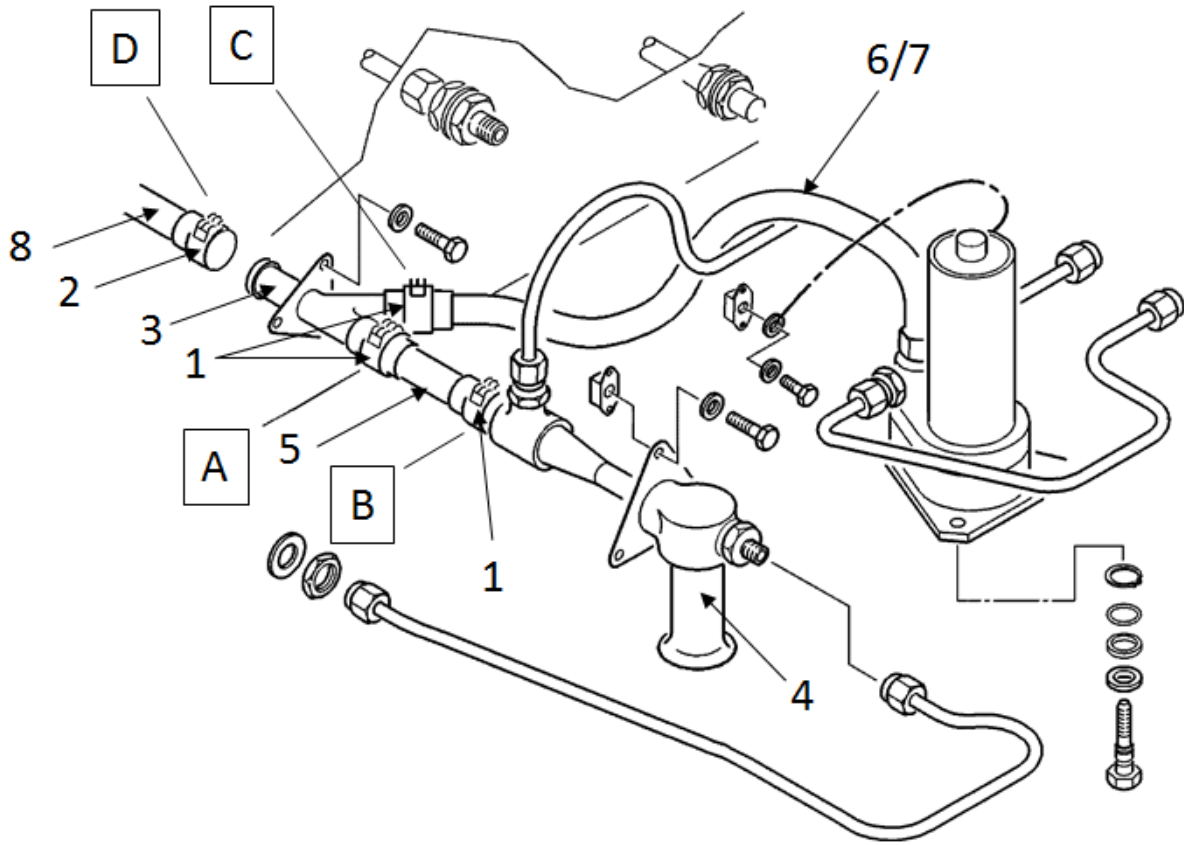

Figure 2: Clamp Identification and Findings for Reporting

Wing	Location A	Location B	Location C	Location D
P/N	14C02-10A	14C02-10A	14C02-10A	14C02-12A
LH				
RH				

FH since incorporation of SB-328-28-490:	
FC since incorporation of SB-328-28-490:	

NOTE: LH installation shown. RH installation mirrored.

NOTE: Please add the filled page to the compliance record form of this ASB.



3 MATERIAL INFORMATION

A Material Parts List

Item	Part Number	Qty.	Nomenclature	Remarks
1	14C02-10A	A/R	Clamp	New clamps are only necessary if damaged clamps are found.
2	14C02-12A	A/R	Clamp	
3	001A282A1020200	A/R	Connection Part	New parts are only necessary if depth of chafing marks is more than the replacement limits.
4	219335-3	A/R	Fuel Jet Pump	
5	001A282A3099200	A/R	Tube Assy	
6	001A282A3235000	A/R	Tube (LH)	
7	001A282A3235001	A/R	Tube (RH)	
8	001A282A3175000	A/R	Tube Assy	



**Dornier 328
Compliance Report**

328 Support Services GmbH

Customer Support • Global Support Centre
P. O. Box 1252 Phone: +49 8153 88111 6666
D-82231 Wessling Telefax: +49 8153 88111 6565
Germany E-Mail: gsc.op@328.eu



Please complete this compliance form for each aircraft only when it is applicable, and mail, e-mail, or fax to:

328 Support Services GmbH
Global Support Centre
P. O. Box 1252
D-82231 Wessling
E-Mail: gsc.op@328.eu
Telefax: +49 8153 88111 6565

From Company: _____

Doc. No.	Rev.	Title
ASB-328-28-041	2	Fuel – Inspection of fuel line clamps

Aircraft Serial Number: _____

Operator: _____

Total Flight Hours: _____ Total Landings: _____

Date of Compliance: _____

Comments: _____

Date

Authorized Signature